

JS-25 „COMBO“ P.I.R. & glass break detector

The JS-25 COMBO is an outstanding “two in one” detector, which dramatically simplifies alarm installations.. This detector combines two sensors (P.I.R. motion & acoustic glass break) in one housing. It provides three independent outputs (P.I.R. alarm, glass break alarm and tamper).

The signal from the P.I.R. sensor is electronically analyzed. This ensures that the detector provides excellent sensitivity and at the same time false alarms are basically eliminated. The detection analysis rate can be adjusted to increase its immunity if the JS-25 is installed in a problematic location. The standard lens in the detector can be replaced with an optional corridor or pet immune lens.

The dual technology glass break detector analyses air pressure changes and sounds to detect the breaking of a glass window. The signal processing guarantees a high sensitivity to the breaking of all types of glass. The sensitivity can be adjusted to match various window sizes and mounting distances. A memory feature enables the user to determine, visually, which detector triggered the alarm.

For testing, the JS-25 is equipped with two LED indicators (red confirms a P.I.R. alarm, green confirms a glass breaking alarm).

The COMBO distinguishes itself as a unique 2 in 1 solution with excellent RF immunity.

Specification

Power supply:	12 V DC \pm 25%
Power consumption (LED off):	max. 10 mA
Maximum consumption (LED on):	max. 35 mA
Terminals size:	max. 1 mm ²
Tamper output:	max. 60 V / 50 mA, internal resistance max.16 Ohm
Environment	II. – general indoor, (EN 50131-1)
Operating temperatures	-10 to +55 °C
Security level	grade 2, EN 50131-1
Mounting height:	2.5 m above floor
Initialization:	typ. 1 minute
Complies with the essential requirements of: 89/336/EC EMC Directive - Protection concerning electromagnetic compatibility when is used for its intended purpose. Original of the conformity assessment can be found at the web page www.jablotron.cz , section Technical support.	



Motion detector specification:

Detection range:	120° / 12 m (standard lens)
PIR alarm output:	normally closed, max. 60V / 50 mA, internal resistance max.30 Ohm

Glass break detector parameters:

Detection range:	max. 9 m
Minimum glass dimensions:	0.6 x 0.6 m
Alarm output:	normally closed, max. 60V / 50 mA, internal resistance max.16 Ohm

The product is CE marked.

Installation

The detector is designed for indoor applications. It can be mounted on a flat wall or in a corner. Do not place the detector close to any heating/cooling vents or near any other object that often changes temperature. Do not place the detector close to any apparatuses that can generate air pressure changes, low frequency noise or vibrations.. The unit must have an unobstructed view of the protected area and glass.

1. **Open the cover of the detector** (press in the plastic tab on the bottom with a screwdriver).
2. **Disconnect the cable** connecting the front cover with the main PCB.
3. **Remove the main PCB** by pressing the flexible tab.
4. **Punch through the pre-formed holes** for cables and screws.
5. **Attach the housing to the wall** (2.5 meters above the floor).
6. **Return the PCB into the housing** and connect wires to the terminals.
7. **Re-connect the cable and attach the cover.**

Note: Avoid touching the P.I.R. sensor!

Terminals

+12V, GND	power supply
PIR, PIR	P.I.R. alarm output (normally closed)
TMP, TMP	TAMPER output (normally closed)
GBS, GBS	glass break alarm output (normally closed)

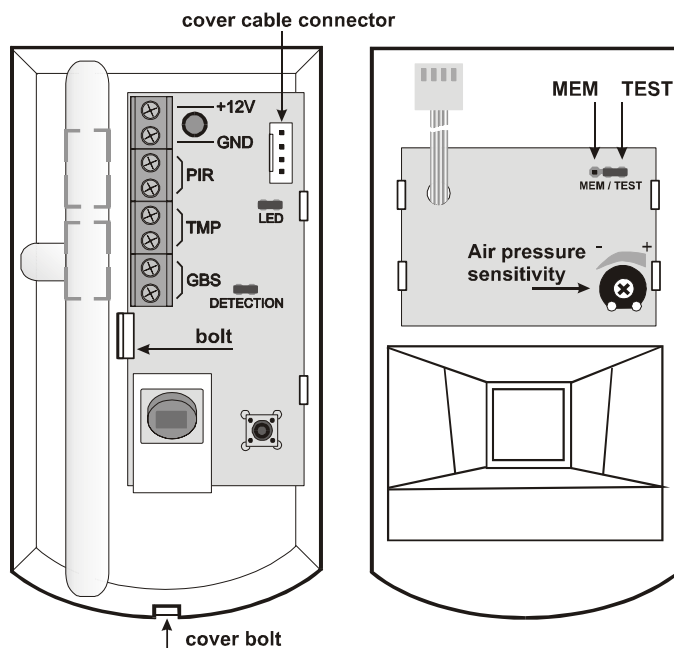

Jumpers

- LED** the red PIR indicator can be disabled by opening this jumper
- DETECTION** removing this jumper enables a higher rate of analysis and increases the immunity of the PIR detector. This setting is suitable for problematic locations with temperature changes or electromagnetic interference.
- MEM/TEST** sets the green LED glass break indicator. In the **TEST** position, this LED indicates air pressure changes by a quick flash and an alarm triggering by a long flash. In the **MEM** position the LED indicates a broken glass alarm memory. When the jumper is disconnected, the green LED is disabled.

PIR detector testing

- After switching on the power wait for 1 minute. During this period the detector initializes and stabilizes its parameters (red LED will be on if not disabled).
- Each detected movement will be indicated by the detector's red indicator (if not disabled).
- Check if the detector covers the protected area as you expected.

Glass break detector testing and adjustments

Set the MEM/TEST jumper to the TEST position (green LED will indicate the triggering).

- Strike carefully the glass with a cushioned instrument. *Attention*, do not break the glass!
- The green LED will flash shortly after a strike, if the air pressure sensor sensitivity is suitably set. The sensitivity can be adjusted using the variable resistor. Do not adjust too an excessively high sensitivity.
- For complete testing of the detector it is recommended to use the GBT-212 glass break simulator. The green LED will light for 2 seconds if glass breaking is detected.

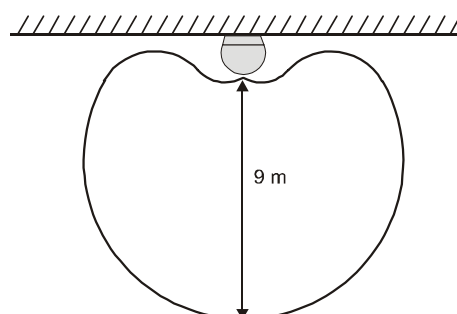

glass break detector working range diagram

Notes for the glass break detector operation

- a) The memory function can be used to determine the source of an alarm in the system. If several detectors are used in one zone, you can set the MEM/TEST jumper into the MEM position. Then, if this detector triggers an alarm, the green LED will remain on until the MEM/TEST jumper is disconnected. The detector operates as usual even while the alarm memory is indicated.
- b) If there is any automatic device in the protected area which can generate a loud noise (air conditioning, heating or cooling systems etc.), ensure that this noise does not trigger the glass break sensor. If it does, it is necessary to relocate the detector or assure that these devices will not be on when the security system is armed.
- c) A glass break detector located at the entrance can trigger a false alarm when the door is opened (air pressure change combined with keys clinking on the glass or a door's squeaking can simulate the sound of glass breaking). It is recommended to connect the glass break detector into the delay zone of a control panel.

PIR detector lenses

Standard lens that is supplied with the JS-20 Largo detector covers an area of 120 degrees / 12 meters. See the diagram on the right.

For special applications other lenses can be used. Optional lenses for long corridors and areas with small animals are supplied separately.

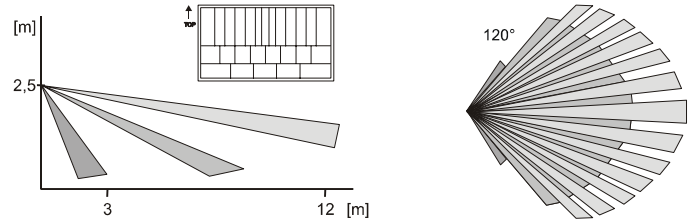

Pet lens is marked JS-7906. This lens prevents animals smaller than 40 cm from being detected. The working range of this lens is reduced to 7 meters. It is recommended to test this lens carefully with the animal when installing the system, in order to prevent false alarms.

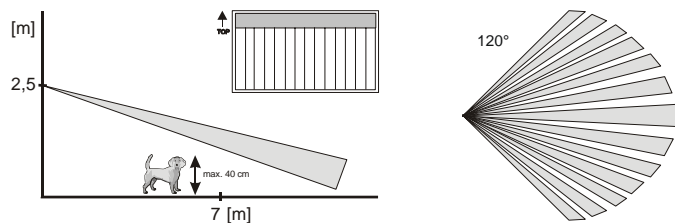

Corridor lens is marked JS-7904. The working range of this lens is 25 meters long and only 3 meters wide. It is recommended to test the detector's sensitivity carefully when installing it into a corridor.

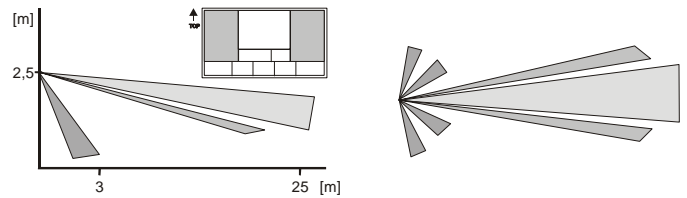

Examples of the detector wiring

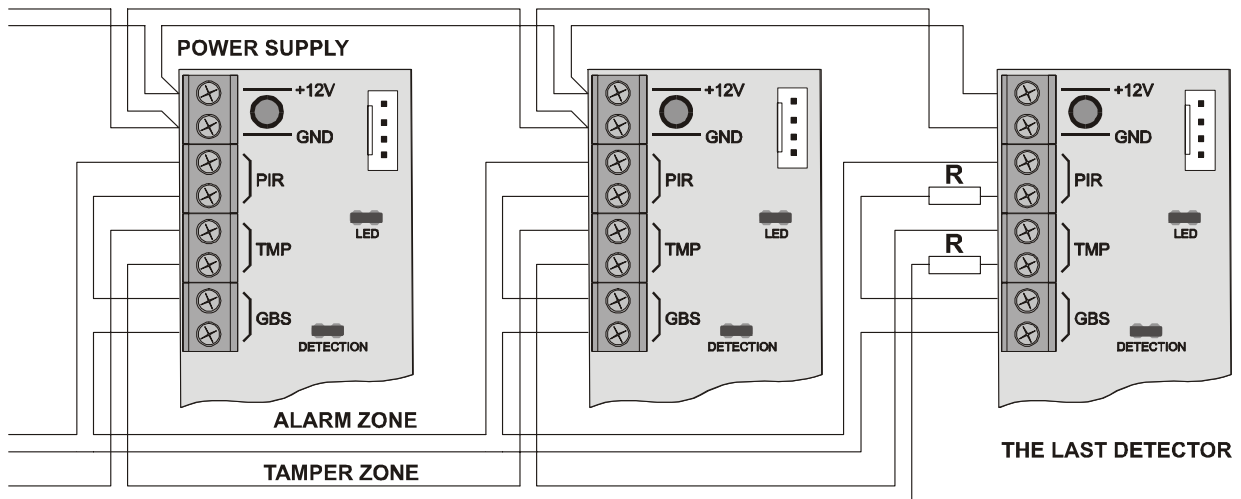

Example of wiring several detectors into one EOL alarm and tamper zone.

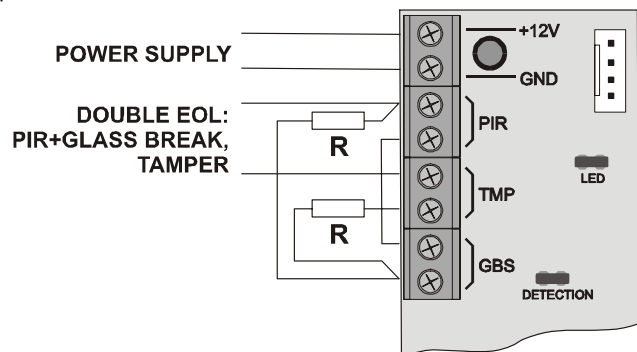

Example of wiring the JS-25 into the double EOL zone.

Note: Although this product does not contain any harmful materials we suggest you to return the product to the dealer or directly to the producer after usage.

