

# The OS-360/365 outdoor siren

The OS-360/365 is an hardwired outdoor backup siren combining a loud acoustic siren with a flashing light. The high-powered flashing light helps to locate the active siren.

**Model OS-360 is equipped with a piezo-electric siren** mainly suitable for urban areas with a high building density. If necessary another piezo-electric siren (ACM-OS360) can be used.

**Model OS-365 is equipped with a magneto-dynamic horn siren** mainly suitable for family houses or for buildings with more space around them.

Two tamper switches are built into the unit. They react to removing the cover from the unit or removing the siren from the wall. The siren's housing is made of mechanical, weather and UV-resistant plastic. The circuit board is protected against air humidity by a double layer of varnish.

## Specification

Power supply	10 to 17 V DC
Current Consumption	< 50 mA / 12 V
Backup battery	NiCd pack 4.8 V / 1800 mAh Lifetime approx. 3 years
Piezoelectric siren (OS-360) sound level	113 dB / 1 m
With second piezo-electric siren (ACM-OS360)	118 dB / 1 m
Electro-acoustic siren (OS-365) sound level	110 dB / 1 m
Siren timer	19 minutes
Flasher timer	60 minutes
Resistance of the tamper loop in stand-by	< 70 Ω
Enclosure	IP 34D
Security grade 3 (with internal cover)	EN 50131-1
Security grade 2 (without internal cover)	EN 50131
Environmental class IV	-25 to +60°C
Dimensions	230 x 158 x 75 mm

Hereby, Jablotron Ltd., declares that this OS-360/OS-365 is in compliance with the essential requirements and other relevant provisions of 73/23/EC Low Voltage Directive and 89/336/EC EMC Directive.

Original of the conformity assessment can be found at the web page [www.jablotron.com](http://www.jablotron.com), section Technical support.



## The terminal block connections

**+12V** - power voltage (+10 to 17V)

**GND** – ground

Power supply voltage drops cause the siren and the flasher to activate.

**SIR** - disconnection from GND will cause activation of the siren.

**FLA** – disconnection from GND will cause activation of the flasher.

**ARM** – a terminal for additional features. Its function depends on the setting of the CHIRP and FLASH jumpers (see table 2).

**TMP, TMP** - NC tamper switch output (connected in series with the 68R protection resistor)

There are also NiCd backup battery and siren connectors. **The NiCd backup battery comes from the factory disconnected. Only connect it during installation.**

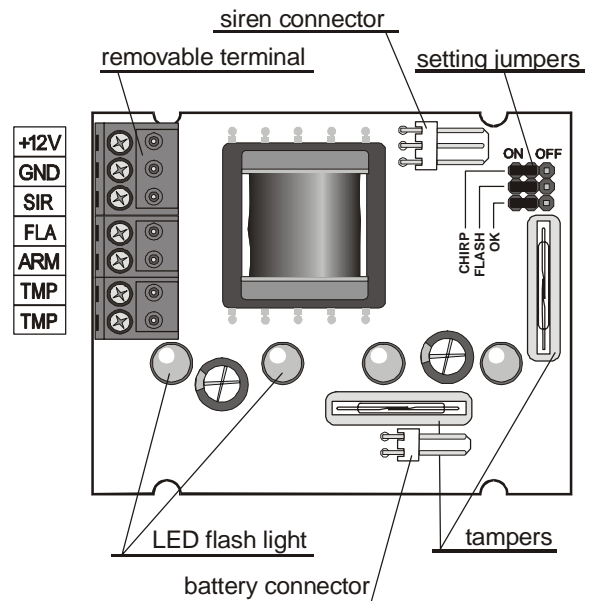

Picture 1 the top side of the electronic circuit board

Terminals **ARM**, **FLA** and **SIR** can also be used for the remote measurement of the backup battery voltage without the necessity of climbing up to the siren. Measurement is always made on a single disconnected cable against GND, directly in the control panel – see Table 1.

<b>ARM</b> disconnected	Voltage of the charging battery
<b>FLA</b> disconnected	Flasher activated – battery is loaded by 100mA
<b>SIR</b> disconnected	Siren activated – battery is loaded by 1A

Table 1

## The setting jumpers

There are three jumpers on the PCB (Picture 1 shows their location) to select the optional functions:

<b>CHIRP</b>		<b>ON</b> - one chirp on connecting ARM to GND, and 2 chirps sound on disconnecting from GND
		<b>OFF</b> – chirps are disabled
<b>FLASH</b>		<b>ON</b> - flashing for 60 minutes after siren deactivation (connection of FLA to GND) Any change on the ARM line will terminate flashing immediately
		<b>OFF</b> - flashing is terminated immediately when FLA is connected to GND
<b>OK</b>		<b>ON</b> the siren flashes once every 45 sec. (confirmation of readiness)
		<b>OFF</b> – indication is disabled

Table 2

## Do not place the siren near eaves where ice could form in winter.

- Remove the plastic cover by removing the two screws (under plastic caps) with a screwdriver
- Route all cabling into the siren through the desired hole on the rear part
- Fix the siren in the desired place by hanging the siren housing on the top screw and fix it using two other screws.
- Connect the wires from the control panel to the siren (see the examples of connections on Picture 2). For more comfortable installation, the terminal can be taken off the main board (by pulling the terminal up off the board). **Check the proper position of the terminal while it is being put back.**
- Fix the cable using the plastic holder which is to the left of the board
- Connect the back-up battery
- Assemble the siren and tighten the screws
- Insert the plastic caps onto the screws

**Please keep in mind the high acoustic power of the siren and protect your hearing during testing.**

## Finishing installation

The following conditions are necessary for the OS-360/365 to be ready:

1. **SIR** terminal connected to GND
2. **FLA** terminal connected to GND
3. Connected and charged **NiCd battery** (voltage higher than 4 V)
4. Power supply connected to the **+12 V** and **GND** terminals

The siren will flash once after 2 seconds and if the battery is charged enough the siren will shortly sound in 45 seconds to confirm operational readiness. If the battery is discharged the start-up cycle is repeated until the battery is charged enough. This will be confirmed by a short siren sound.

### Functions:

**Power supply failure** will cause the activation of both the siren and flasher. When the power supply is restored siren, sounding and flashing will be terminated in 10 seconds. If the power supply is permanently disconnected, the siren will be switched off automatically in 19 minutes.

**Disconnecting SIR from GND** - will cause the siren to be activated (but without flasher activation). If SIR is connected back to GND the siren sounding will be terminated immediately. Otherwise the siren will be automatically deactivated in 19 minutes.

**Disconnection of FLA from GND** - will cause the flasher to be activated (but without siren activation). If FLA is connected back to GND, flashing will be terminated immediately or in 60 minutes depending on the settings (this time can be shortened by any change in the ARM input).

**Change of ARM input** – if the CHIRP jumper is in the ON position, then on connection of ARM to GND the siren will make one chirp and the flasher will flash briefly. On disconnection from GND the siren will make two chirps and the flasher will flash twice. If the flasher is flashing due to FLA activation, then any change in the ARM input (connection or disconnection from GND) will terminate the flashing. (The FLA terminal must be deactivated – connected to GND).

**Stand-by** – if the SIR and FLA inputs are connected to GND, there is a proper power supply, the backup battery is charged and the OK jumper is in position ON, then the siren will flash once every 45 seconds.

## Example of use

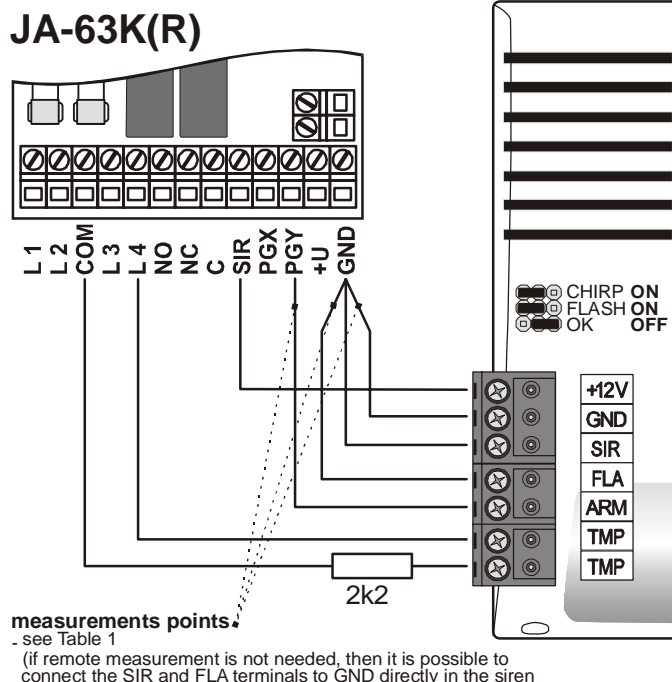

Picture 2 example of connection to the JA-63K(R) control panel

In this configuration the siren and the flasher are activated during an alarm from the control panel. Arming and disarming are confirmed by chirps. Flashing is terminated immediately after disarming the control panel regardless of the setting of the FLASH jumper. The battery voltage can be measured at the measurement points shown – see Table 1.

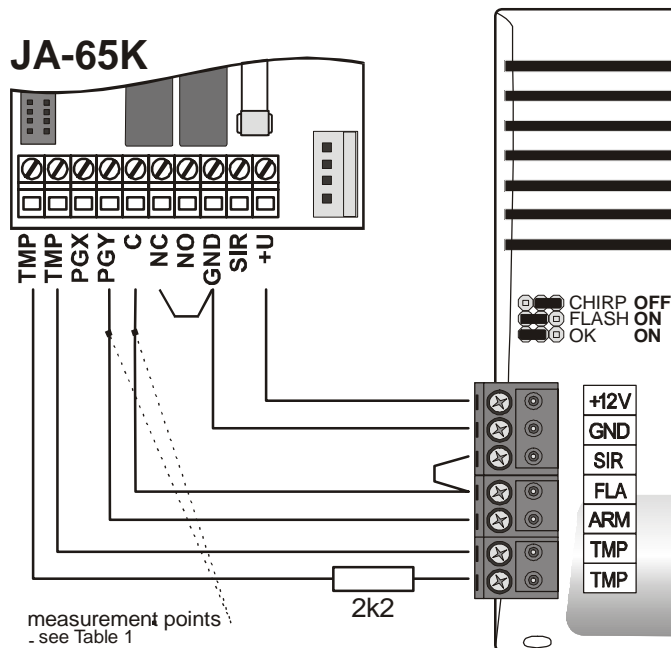

Picture 3 – example of connection to the JA-63K(R) control panel

In this configuration, the siren sounds for the duration of the alarm. Additionally the flasher flashes for another 60 minutes. Flashing can be terminated by arming or disarming. The chirps are disabled and the flasher will flash once every 45 seconds to confirm operational readiness of the siren. The battery voltage can be measured at the measurement points shown – see Table 1.

## Maintenance

The siren does not need any special maintenance. The lifetime of the NiCd battery is about 3 years, depending on the working conditions. If the power supply (+12V and GND) is cut off for longer period of time, then also disconnect the battery. The battery can be checked remotely (see Table 1).

### Note:

**In order not to activate the siren before disconnecting the power supply, first disconnect the battery.**

**Warning! If the siren is activated when the siren connector (see picture 1) is being disconnected, the siren will not be damaged, but there will be high voltage on the terminal.**



**Note:** There is NiCd battery containing Cd (cadmium) Although this product does not contain any harmful materials we suggest you to return the product to the dealer or directly to the producer after usage.



Pod Skalkou 33  
466 01 Jablonec nad Nisou  
tel.: 483 559 999  
fax: 483 559 993  
Internet: www.jablotron.com